



Applicative Sensors







VBR series

Vibrations and inclination sensor



Vibrations and inclination

features

- M18 housing
- AISI316L stainless steel housing (front included)
- IP67 protection degree



web contents



- Application notes
- Photos
- Catalogue / Manuals



code description

VBR 1 / D 0 - 3 A

series	VBR	Vibrations and inclination sensor
housing	1	M18 short housing
	D	RS485 programming
exit	0	RS485 + analogue output
	3	Full AISI316L housing
conness.	A	Cable exit
	V	M12 pigtail cable exit



technical specifications

Vibrations and inclination

VBR1/D0-3*	
operating voltage	24 Vdc +/- 20%
power consumption	< 1 W
operative range	+/- 16 g (MAX)
resolution	15.62 mg @ +/- 2 g 31.25 mg @ +/- 4 g 62.50 mg @ +/- 8 g 125 mg @ +/- 16 g
detection axes	3 (X, Y, Z)
frequency range	0...400 Hz
technology	MEMS (Micro Electro-Mechanical Systems)
digital output	RS-485 (addressable) 57600 Baud rate - 1 bit stop - parity
resolution digital output	16 bit @ RS-485 (complementary to 2) 12 bit @ analogue output
voltage analogue output	0..5 V / 0..10 V (programmable)
current analogue output	4..20 mA / 0..20 mA / 0..24 mA (programmable)
load resistor (voltage)	1k...1M Ohm
load resistor (current)	100...500 Ohm
humidity	< 80 % without freeze
temperature range	-25° C...+ 70°C
storage temperature	-30°...+90°C without freeze
electrical protections	polarity reversal transient
protection degree	IP 67 (EN60529)
housing material	AISI316L PA12
connections	cable 5 poles pig Tail M12 5 poles
dimensions	M18
weight	100 gr

electrical diagrams of connections

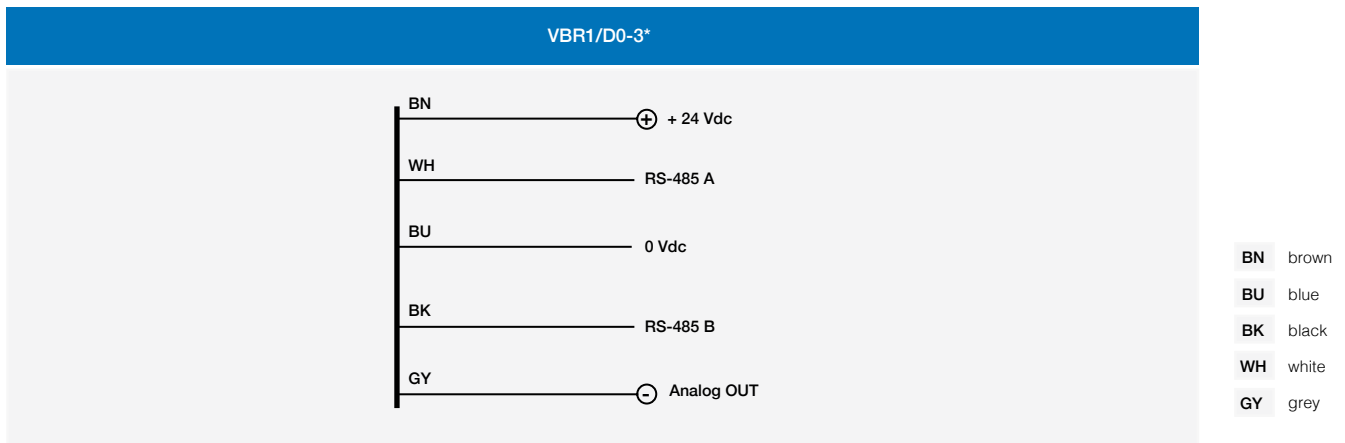

VBR

dimensions (mm)

VBR1/D0-3*

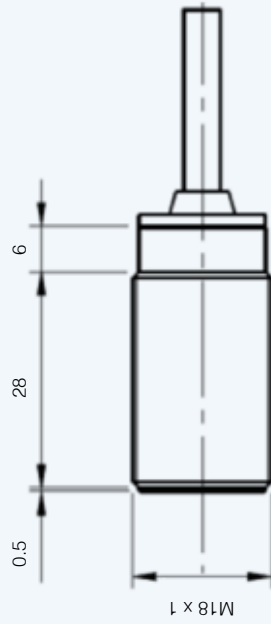

dimensions (mm)

accessories included

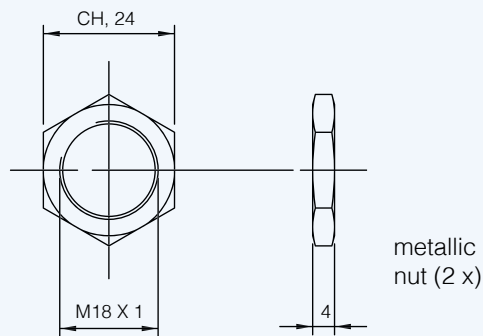

Vibrations and
inclination



axes directions

Vibrations and inclination

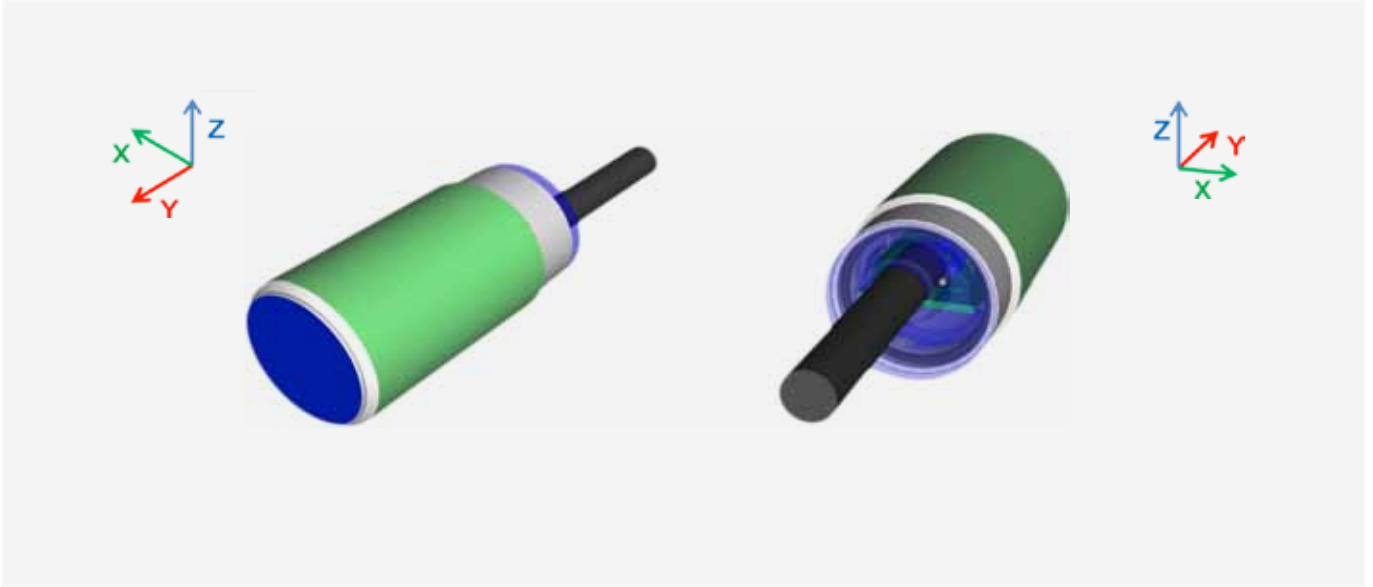

accessories

bracket ST 18 - S

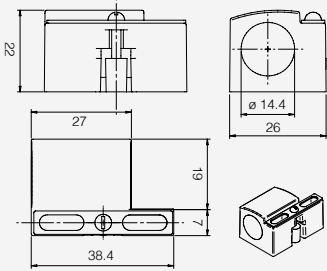
product	to be used with	dimensions (mm)	description / installation
	VBR series		fixing bracket for M18 sensors

bracket ST 18 - V

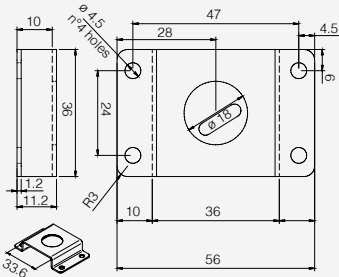
product	to be used with	dimensions (mm)	description / installation
	VBR series		fixing bracket for M18 sensors

connection cables

CD12M/0H-050A5 (PUR, 5 m) **CD12M/0H-100A5** (PUR, 10 m)
CD12S/0H-050A1 (PVC, shielded, 5 m) **CD12S/0H-100A1** (PVC, shielded, 10 m)



UR series

Control unit for miniaturized sensors



Control unit for
miniaturized sensors

features

- The unit allows the mounting of miniature pair of sensors suitable for very harsh environments (DG series)
- LED indicators: alignment (stability), operating voltage, alarm and output state
- Operating voltage AC or DC
- Relay output and relay alarm output
- Double timer with independent adjustments
- Sensitivity adjustment
- Possibility of mounting on panel



web contents



- Application notes
- Photos
- Catalogue / Manuals



code description

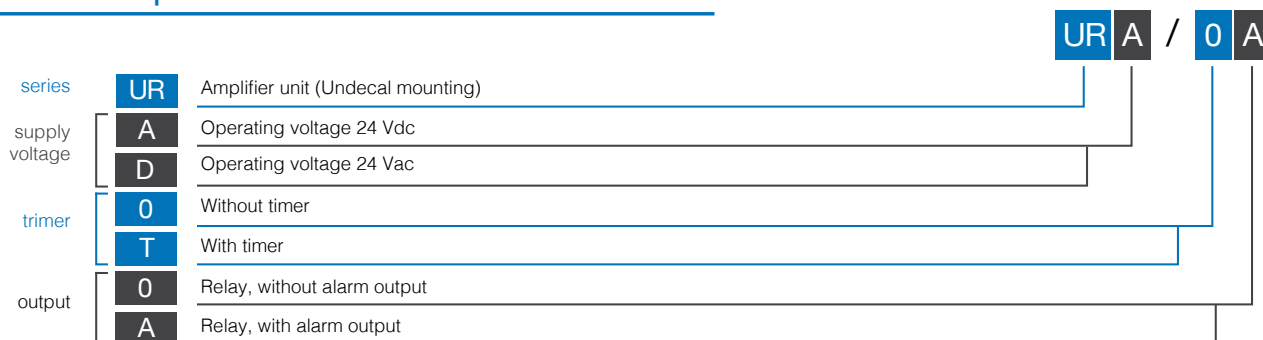

available models

supply voltage	relay without alarm output		relay with alarm output	
	with timer	without timer	with timer	without timer
24 Vdc	URA/T0	URA/00	URA/TA	URA/OA
24 Vac	URD/T0	URD/00	URD/TA	URD/OA



technical specification

Control unit for
miniaturized sensors

	URA/**	URD/**
operating voltage	24 Vdc	24 Vac
frequency	-	50...60 Hz
ripple	≤ 10 %	-
voltage tolerance	± 20 %	+ 10 %...- 15 %
no-load supply current	≤ 100 mA	1,5 VA
operating output	relè NO + NC	
alarm output	relè NO	
max. output voltage	250 V	
max. output current	3 A (resistive load)	
temperature range	- 10°C...+ 50°C (without freeze)	
switching frequency	10 Hz	
electrical life	1.5 x 10 ⁵ operations	
timer functions	3s delay ON and delay OFF selectable with Dip-switch and adjustables separately	
operating time (relay de-energized)	40 ms max	
reset time (relay energized)	40 ms max	
protection degree	IP20 (EN60529)	
EMC	conforming to directive CE 2004/108/CE according with EN 60947-5-2	
LED indicators	green (supply), red (output state), green (stability), red (alarm)	
housing material	Noryl 90 V - 0	
weight (approximate)	110 g	

electrical diagrams of the connections

UR*/**

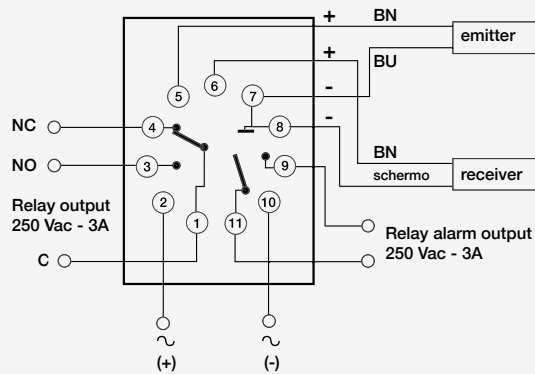

- BN brown
- BU blue
- BK black
- WH white
- PK pink
- GY gray



UR*/**

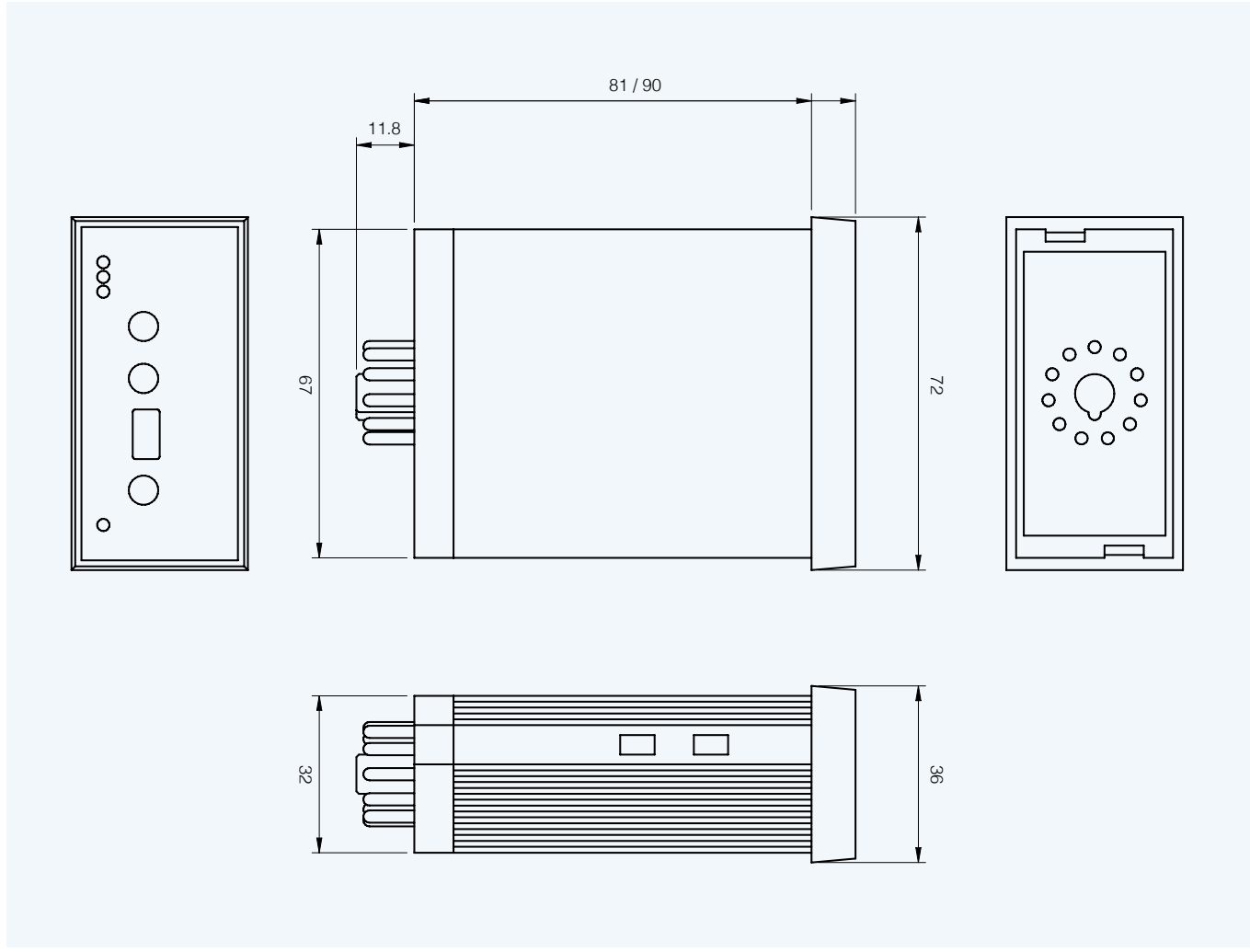

Holes dimensions for mounting on panel: 68x33 mm.
Undecal Socket (STZ3) supplied separately.



notes

Control unit for
miniaturized sensors

Area for handwritten notes, consisting of multiple horizontal lines.



DG series

Miniature photoelectric sensors



Photoelectric sensors
with preamplifier

features

- IP68 photoelectric sensors for applications in harsh environment
- Sensing distance 60 m (HI), 30 m (LO)
- Approvals: CE



web contents



- Application notes
- Photos
- Catalogue / Manuals



code description

DG E / 0 0 - 0 A

series	DG	Miniaturized sensors Ø 10 mm
emitter / receiver	E	Emitter
	R	Receiver
type	0	Emitter and receiver with preamplifier
	0	46 mm (only available in aluminium)
	1	41 mm (only available in polycarbonate and in M12 steel)
housing materials	2	36 mm (only available in polycarbonate and in M12 steel)
	0	Polycarbonate housing ø10 mm
	1	Aluminium housing with glass optic ø10 mm
cable length	2	M12 steel housing
	A	5 m cable
	B	0 m cable
	C	15 m cable

available models

housing	housing length (mm)	emitter			receiver		
		5 m cable	10 m cable	15 m cable	5 m cable	10 m cable	15 m cable
polycarbonate housing ø10 mm	41	DGE/01-0A	DGE/01-0B	DGE/01-0C	DGR/01-0A	DGR/01-0B	DGR/01-0C
	36	DGE/02-0A	DGE/02-0B	DGE/02-0C	DGR/02-0A	DGR/02-0B	DGR/02-0C
aluminium housing with glass optic ø10 mm	46	-	DGE/00-1B	DGE/00-1C	-	DGR/00-1B	DGR/00-1C
M12 stainless steel	41	DGE/01-2A	DGE/01-2B	DGE/01-2C	DGR/01-2A	DGR/01-2B	DGR/01-2C
	36	DGE/02-2A	DGE/02-2B	DGE/02-2C	DGR/02-2A	DGR/02-2B	DGR/02-2C



technical specification

Photoelectric sensors
with preamplifier

	DG*/1-0	DG*/2-0*	DG*/0-1*	DG*/1-2*	DG*/2-2*
housing length	41 mm	36 mm	46 mm	41 mm	36 mm
sensing distance	75 m	32 m	60 m	75 m	32 m
emission	infrared (880 nm)				
operating voltage	from UR				
beam angle ⁽¹⁾	± 5°*	± 10°*	± 5°*	± 5°*	± 10°*
interference to external light	20.000 lux				
temperature range	- 20°C...+ 60°C				
protection degree	IP67 (EN60529)				
EMC	in conformity with the EMC Directive according to EN 60947-5-2				
housing type	Ø 10 mm			M12	
housing material	polycarbonate		anodized aluminium	steel	
lens material	polycarbonate		glass	polycarbonate	
cable exit material	PVC				

⁽¹⁾ See characteristic curves

electrical diagrams of the connections

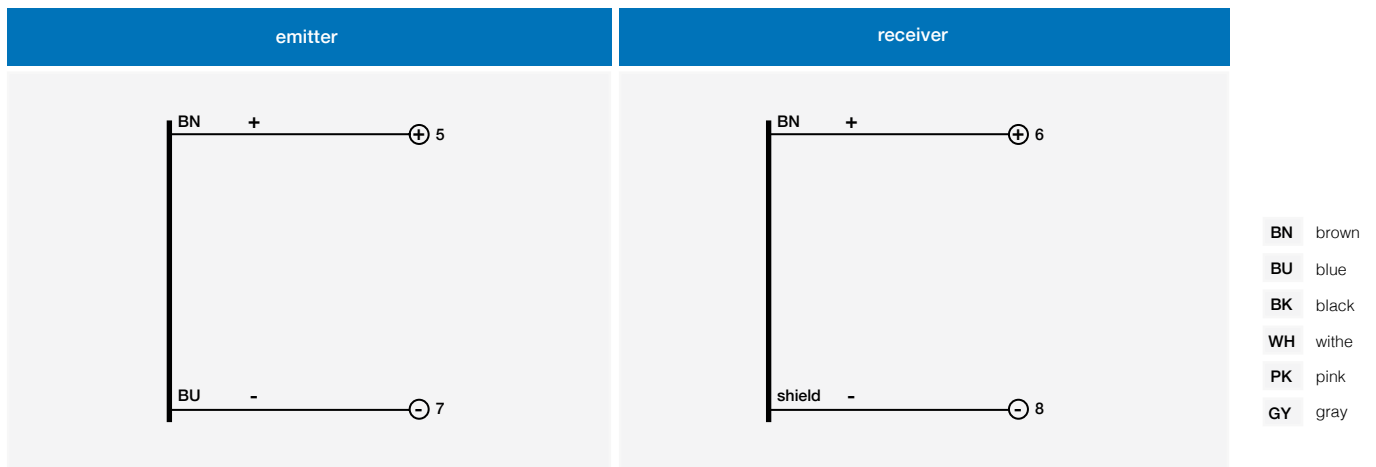

dimensions (mm)

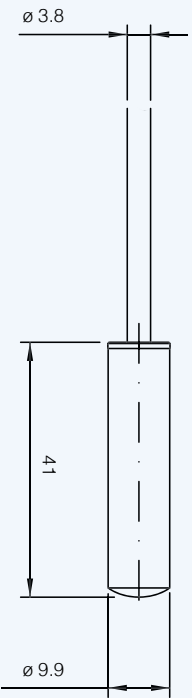
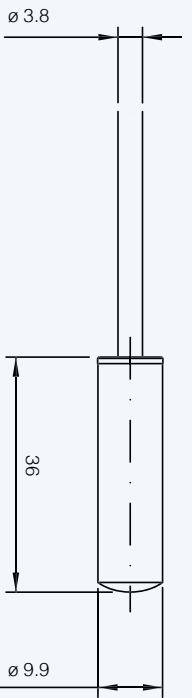
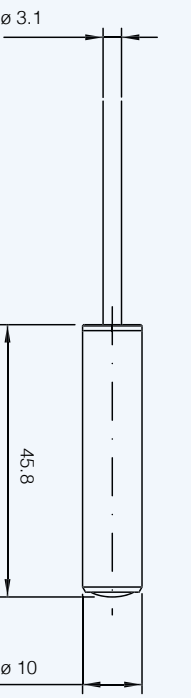
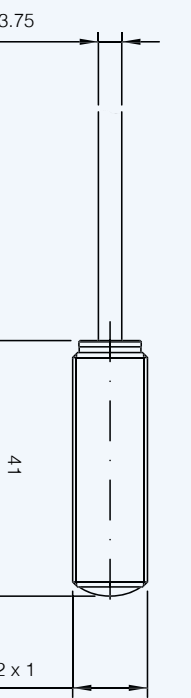
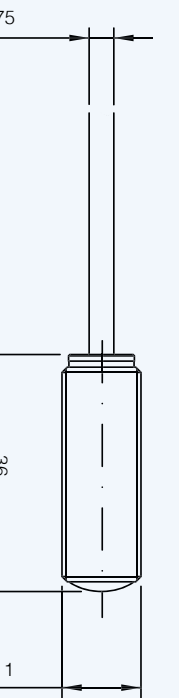
DG*/1-0*	DG*/2-0*	DG*/0-1*	DG*/1-2*	DG*/2-2*
				



Photoelectric sensors
with preamplifier

dimensions (mm)

accessories included in DG*/**-2* models

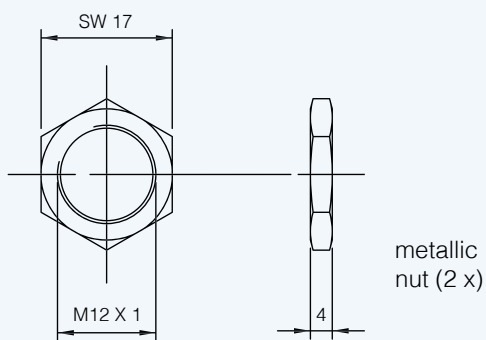



response diagram

Photoelectric sensors
with preamplifier

DG*/0-**

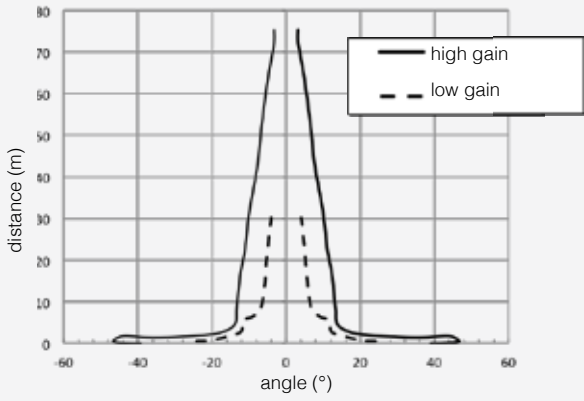

DG*/1-**

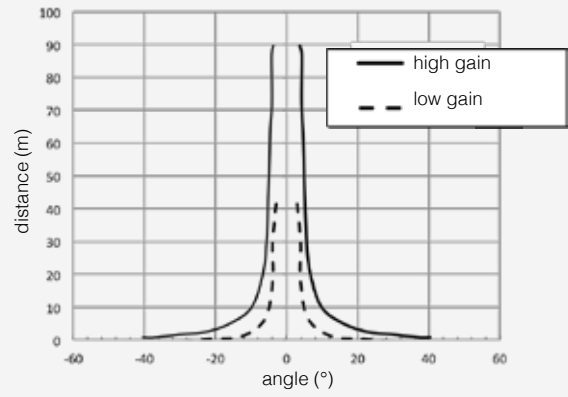

DG*/2-**

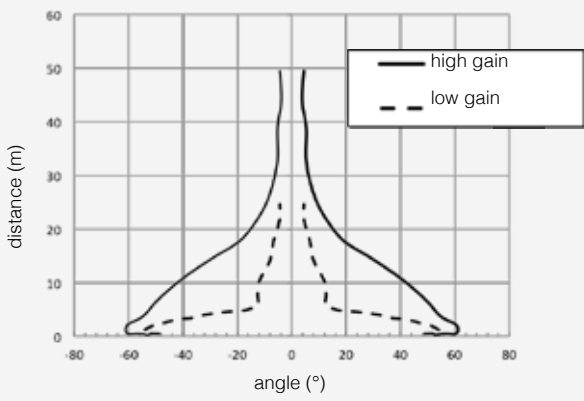



LDL series

Special photoelectric sensors
M18 luminescence scanner - DC



M18 luminescence scanner

features

- With white light emission
- Sensitivity adjustment
- Short response time (50 µs)
- LO/DO selectable outputs
- P65 protection degree
- Complete protection against electrical damages
- Approvals: CE



web contents



- Application notes
- Photos
- Catalogue / Manuals



code description

LDL U / 0 N - 0 C

series	LDL	Ultraviolet light luminescence scanner
housing type	U	M18 housing
LO / DO	0	Selectable LO/DO
output	N	NPN output
	P	PNP output
housing material	0	Plastic housing
cable / plug exit	C	Right-angle cable exit
	K	Right angle plug exit

STF-12 mm focalizer adapter

STF-225 mm focalizer adapter

available models

description	NPN - LO/DO	PNP - LO/DO
right-angle cable exit	LDLU/0N-0C	LDLU/0P-0C
right-angle plug exit	LDLU/0N-0K	LDLU/0P-0K



technical specification

according to IEC EN 60947-5-2

M18 luminescence scanner

	LDLU/**_** + STF-12 ⁽¹⁾	LDLU/**_** + STF-25 ⁽¹⁾
nominal sensing distance ⁽¹⁾	12 mm	25 mm
spot dimension	Ø 1 mm	Ø 0,8 mm
operating voltage	10...30 Vdc	
ripple	< 10 %	
no-load supply current	40 mA	
load current	100 mA	
leakage current	< 10 µA	
voltage drop	≤ 1,2 V max. IL = 100 mA	
output type	NPN or PNP L0/D0 selectable	
switching frequency	10 kHz	
response time	50 µs	
time delay before availability	200 ms	
power supply protections	polarity reversal, transient	
output protection	short circuit (autoreset)	
temperature range	-5°C...+55°C (without freeze)	
EMC	in conformity with the EMC Directive according to EN 60947-5-2	
temperature drift	10 %	
interference to external light	3.000 lux (incandescent lamp), 10.000 lux (sunlight)	
protection degree	IP65 (EN60529) ⁽²⁾	
LED indicators	yellow (output state) - green (supply)	
housing material	PBT	
cable exit material	polycarbonate	
optical material	PMMA	
tightening torque	1 Nm	
weight (approximate)	50 g	

⁽¹⁾ STF-12 & STF-25 - to be ordered separately

⁽²⁾ Protection guaranteed only with plug cable well mounted

electrical diagrams of the connections

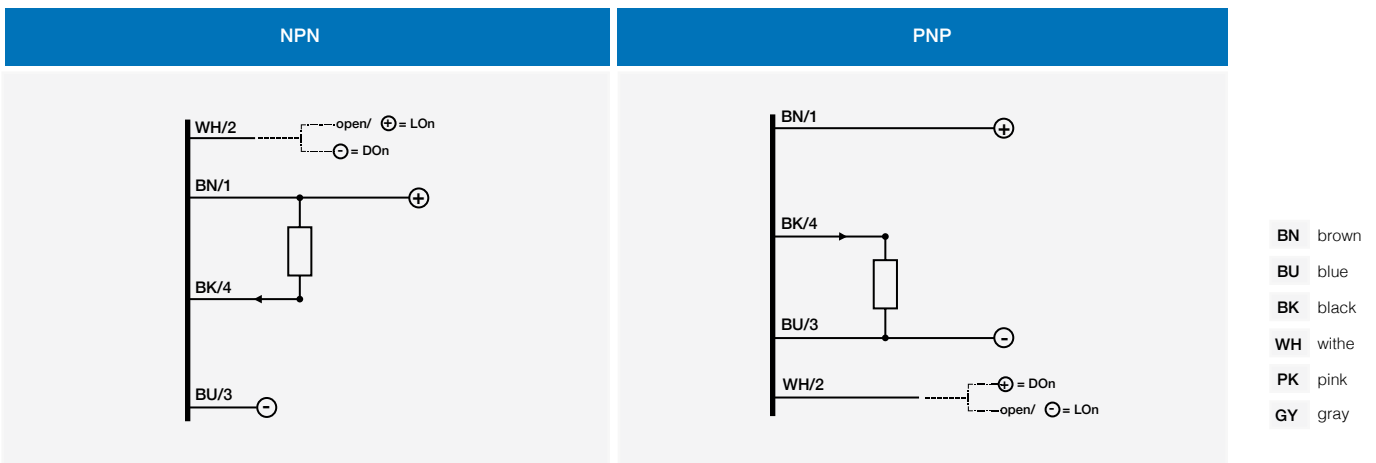

NOTE: In case of combined load, resistive and capacitive, the maximum admissible capacity (C) is 0,2 µF for maximum output voltage and current

M12

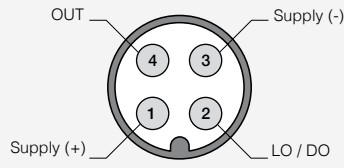

dimensions (mm)

LDLU/**_**

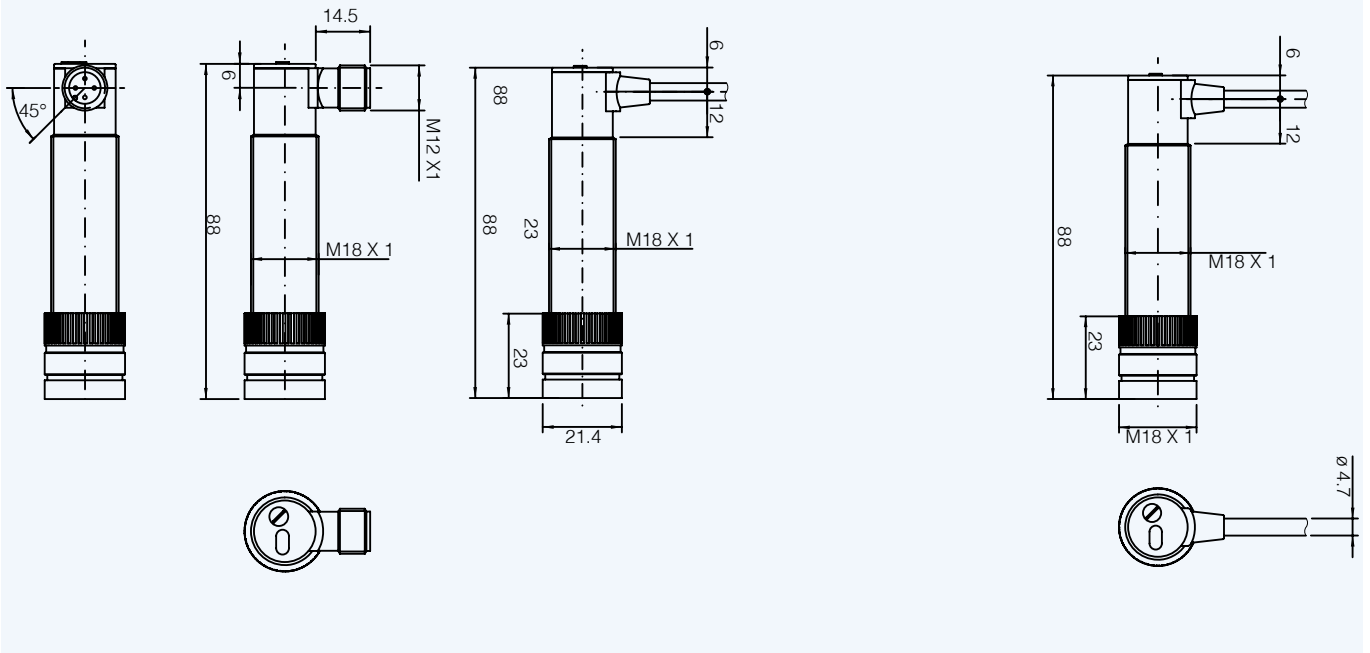

dimensions (mm)

accessories included in all models

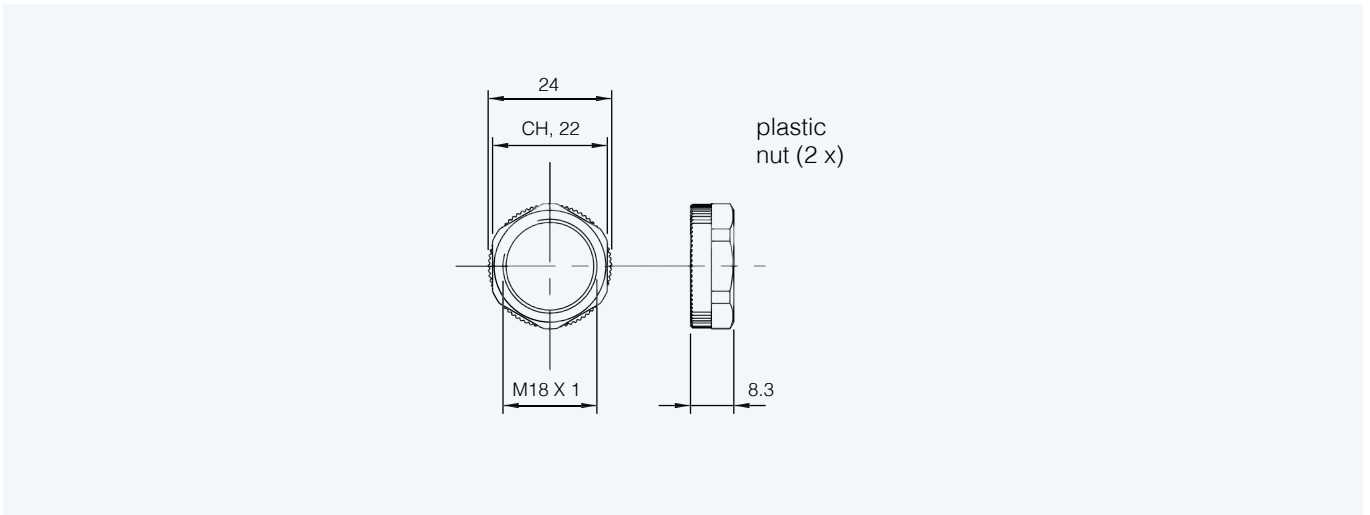



notes

A series of 20 horizontal light blue bars stacked vertically, providing a space for handwritten notes.



LDLV series

Special photoelectric sensors
M30 luminescence scanner - DC



M30 luminescence scanner

features

- Ultraviolet light emission
- Local and remote Teach-in function
- Multifunction LED status indicator
- LO/DO selectable outputs
- Delay off selectable
- Complete protection against electrical damages
- IP65 protection degree



web contents



- Application notes
- Photos
- Catalogue / Manuals



code description

LDLV / 0N - 1K

series	LDL	Ultraviolet light luminescence scanner
housing type	V	M30 housing
LO/DO	0	Selectable LO/DO
output	N	NPN output
	P	PNP output
housing material	1	Metallic housing
plug exit	K	Right-angle plug exit

available models

description	NPN - LO/DO	PNP - LO/DO
right-angle plug cable exit	LDLV/0N-1K	LDLV/0P-1K



	LDLV/**_**
nominal sensing distance ⁽¹⁾	30 mm
spot dimension	3x1 mm
operating voltage	10...30 Vdc
ripple	< 10 %
no-load supply current	20 mA
load current	100 mA
leakage current	< 10 µA
voltage drop	≤ 1,4 V max. IL = 100 mA
output type	NPN or PNP LO/DO selectable
switching frequency	400 Hz
response time	1,1 ms
time delay before availability	200 ms
power supply protections	polarity reversal, transient
output protection	short circuit (autoreset)
temperature range	-5°C...+55°C (without freeze)
EMC	in conformity with the EMC Directive according to EN 60947-5-2
temperature drift	10 %
interference to external light	3.000 lux (incandescent lamp), 10.000 lux (sunlight)
protection degree	IP65 (EN60529) ⁽¹⁾
LED indicators	yellow (output state) ⁽²⁾
housing material	nickel-plated brass
cable exit material	polycarbonate
optical material	PMMA
tightening torque	100 Nm
weight (approximate)	400 g

⁽¹⁾ protection guaranteed only with plug cable well mounted
⁽²⁾ LED's functions are: output state, signal level, teach function

electrical diagrams of the connections

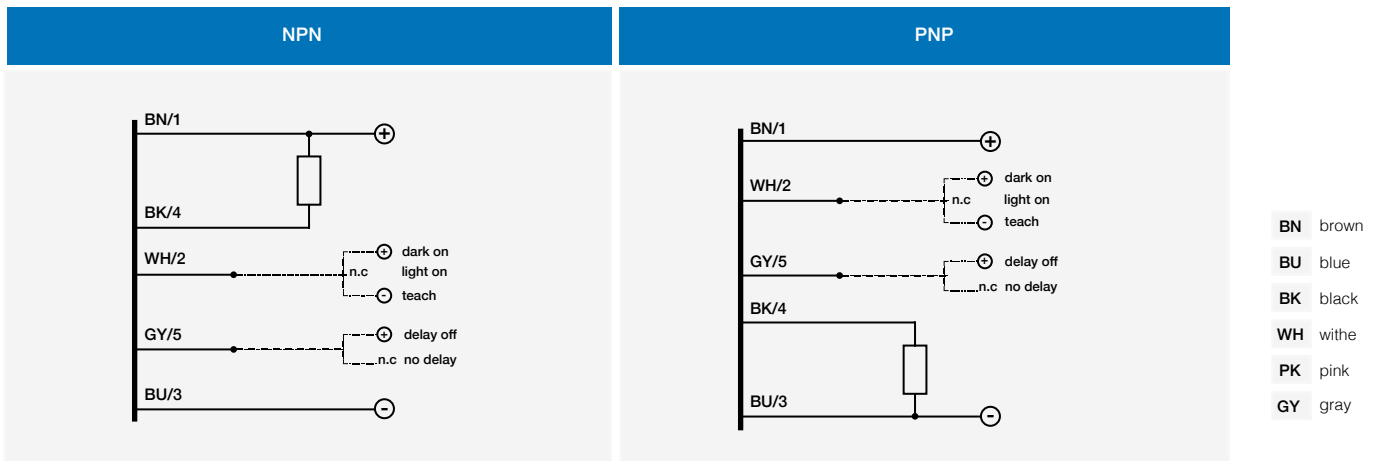

In case both dark on and remote teach functions are necessary, connect a pull-up resistor of 2,2 kΩ between WH/2 and BN/1
 NOTE: In case of combined load, resistive and capacitive, the maximum admissible capacity (C) is 0,2 µF for maximum output voltage and current.

M12

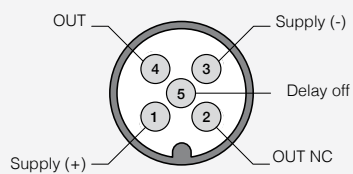

dimensions (mm)

LDLV/**_**

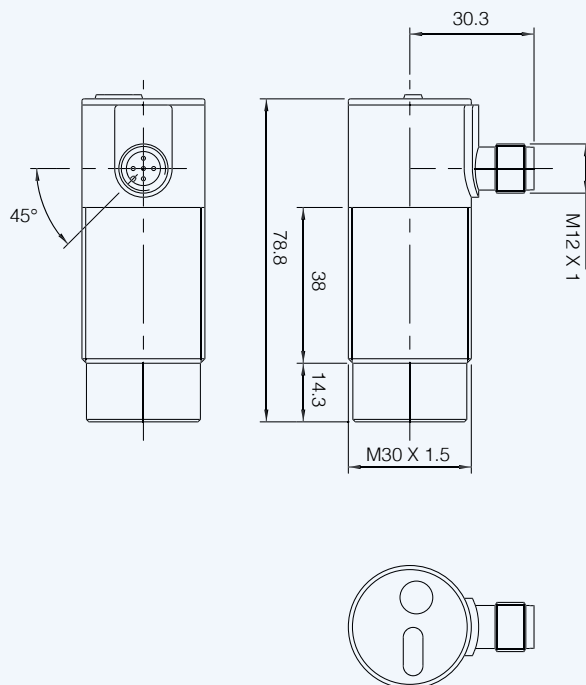

dimensions (mm)

accessories included

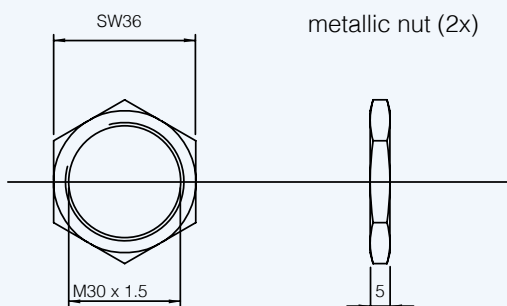



notes

A series of 20 horizontal light blue bars, intended for writing notes.



LTB series

Special Photoelectric Sensors
M18 contrast scanner - DC



M18 contrast scanner

features

- With white light emission
- Sensitivity adjustment
- Short response time (50 µs)
- LO/DO selectable outputs
- P65 protection degree
- Complete protection against electrical damages
- Approvals: CE



web contents



- Application notes
- Photos
- Catalogue / Manuals



code description

LTB / 0 N - 0 C

series	LTB	White light contrast scanner
LO / DO	0	LO/DO selectable
NPN / PNP output	N	NPN output
	P	PNP output
housing	0	Plastic housing
cable / plug exit	C	Right-angle cable exit
	K	Right-angle plug exit

STF-12 mm focalizer adapter
STF-25 mm focalizer adapter

available models

description	NPN - LO/DO	PNP - LO/DO
right-angle cable exit	LTB/0N-0C	LTB/0P-0C
right-angle plug exit	LTB/0N-0K	LTB/0P-0K

LTB



technical specification

Cilindrici M18 DC
LASER

	LTB/**-** + STF-12 ⁽¹⁾	LTB/**-** + STF-25 ⁽¹⁾
nominal sensing distance ⁽¹⁾	12 mm	25 mm
spot dimension	Ø 1 mm	Ø 0,8 mm
operating voltage	10...30 Vdc	
ripple	< 10 %	
no-load supply current	40 mA	
load current	100 mA	
leakage current	< 10 µA	
voltage drop	170 mA	
load current	100 mA on each outputs	
leakage current	≤ 1,2 V max. IL = 100 mA	
output type	NPN or PNP L0/D0 selectable	
switching frequency	10 kHz	
response time	50 µs	
time delay before availability	200 ms	
power supply protections	polarity reversal, transient	
output protection	short circuit (autoreset)	
temperature range	-5°C...+55°C (without freeze)	
EMC	in conformity with the EMC Directive according to EN 60947-5-2	
temperature drift	10 %	
interference to external light	3.000 lux (incandescent lamp), 10.000 lux (sunlight)	
protection degree	IP65 (EN60529) ⁽²⁾	
LED indicators	yellow (output state) - green (supply)	
housing material	PBT	
cable exit material	polycarbonate	
optical material	PMMA	
tightening torque	1 Nm	
weight (approximate)	50 g	

⁽¹⁾ STF-12 & STF-25 - to be ordered separately

⁽²⁾ protection guaranteed only with plug cable well mounted

electrical diagrams of the connections

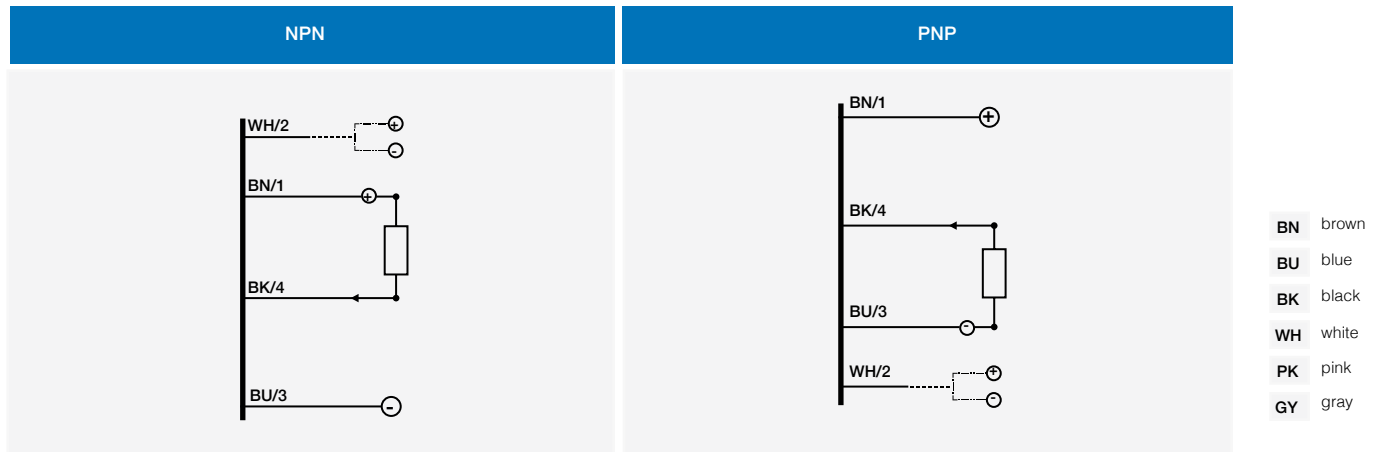

NOTE: In case of combined load, resistive and capacitive, the maximum admissible capacity (C) is 0,2 µF for maximum output voltage and current



M12

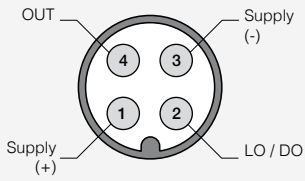

dimensions (mm)

LTB

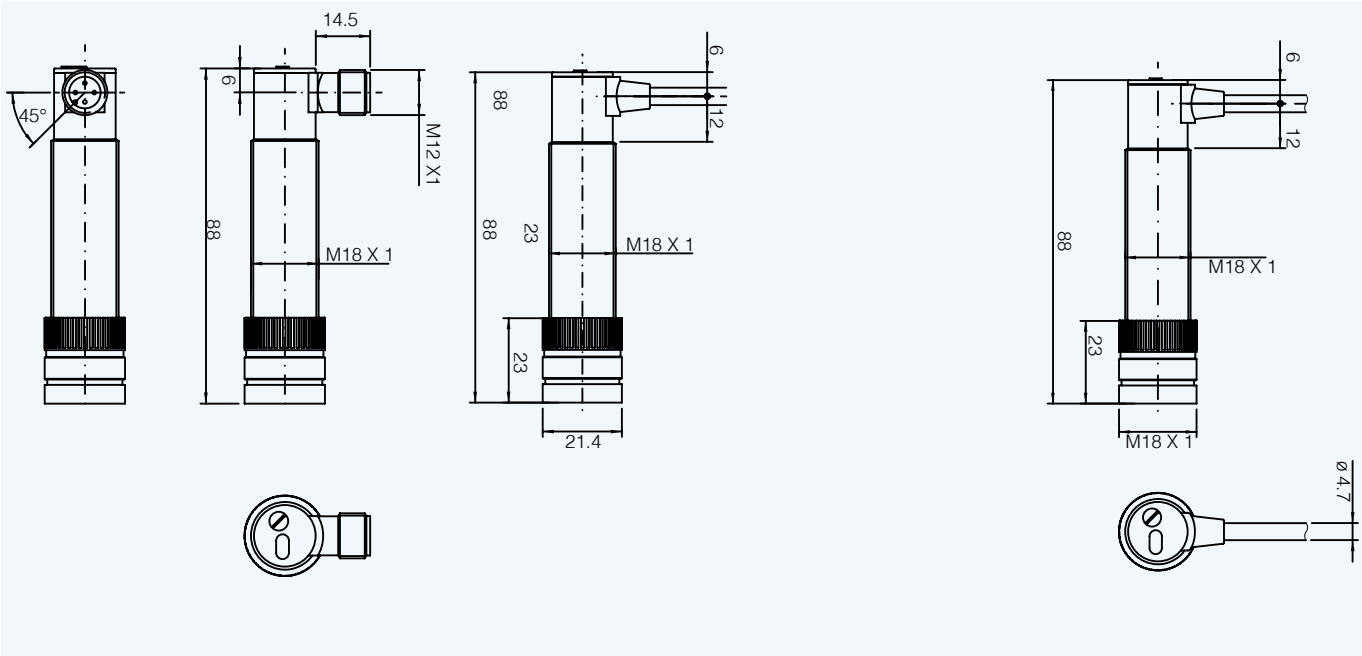

dimensions (mm)

accessories included in all plastic models

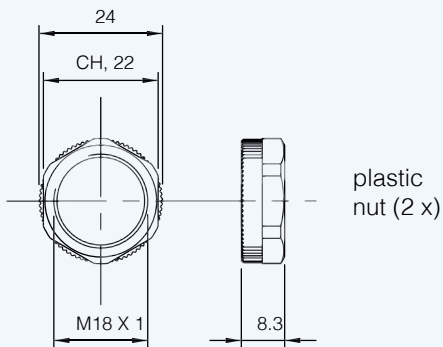



notes

A series of 20 horizontal light blue bars, intended for writing notes.



FC3 series

Dual beams photoelectrics slot sensor for sensor edge detection



Dual beams slot sensor

features

- Dual beams photoelectric slot sensor
- RIAC output
- Light on/Dark on selectable by polarity inversion
- Approvals: CE



web contents



- Application notes
- Photos
- Catalogue / Manuals



ordering system

description	model
Dual beams photoelectric slot sensor for edge detection, Triac output, Output state Light ON/Dark ON selectable by polarity inversion.	FC3
Dual beams photoelectric slot sensor for edge detection, Triac output, Output state Light ON/Dark ON 24 Vdc/ac	FC3/A



	dual beams photoelectric slot sensor for edge detection FC3	dual beams photoelectric slot sensor for edge detection FC3/A
optical axial distance	6,8 mm	
optics diameter	3 mm	
operating voltage	10...30 Vdc	
ripple	< 10 %	
no-load supply current	≤ 30 mA	
load current	max 500 mA (V = 110 Vac)	max 500 mA (V = 30 Vdc / 24 Vac)
leakage current	≤ 250 μA (V = 250 V max)	250 μA (V = 30 V max)
inrush current	5 A (T = 10 μsec)	
output voltage drop	≤ 1,2 V max. (500 mA)	
output type	TRIAC, L0/D0 selectable	MOSFET, L0/D0 selectable
blocking voltage / operating voltage	± 400 V / 110 Vac eff.	±40 / 30 Vdc - 24 Vac eff.
zero-voltage switching	●	-
emission	infrared (880 nm)	
sampling frequency	3,7 kHz	
switching frequency	25 Hz	
supply electrical protection	transient	
EMC	in conformity with the EMC Directive according to EN 60947-5-2	
protection degree	IP64 (EN60529) ⁽¹⁾	
LED indicators	green (supply) - red (output)	
housing material	PCB	
weight (approximate)	122 g	

⁽¹⁾ Protection guaranteed only with plug cable well mounted

electrical diagrams of the connections

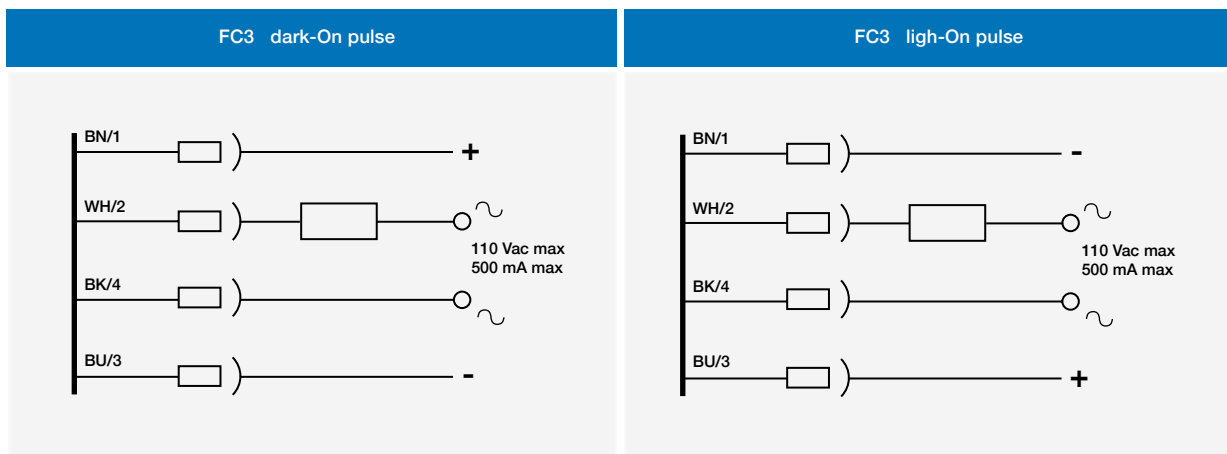

electrical diagrams of the connections

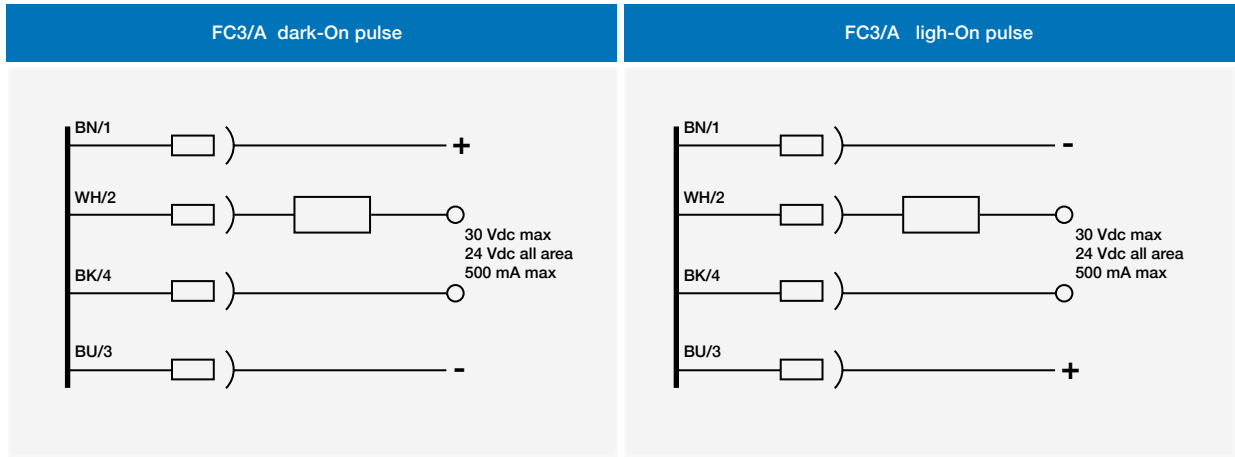

- BN brown
- BU blue
- BK black
- WH white
- PK pink
- GY gray

plug

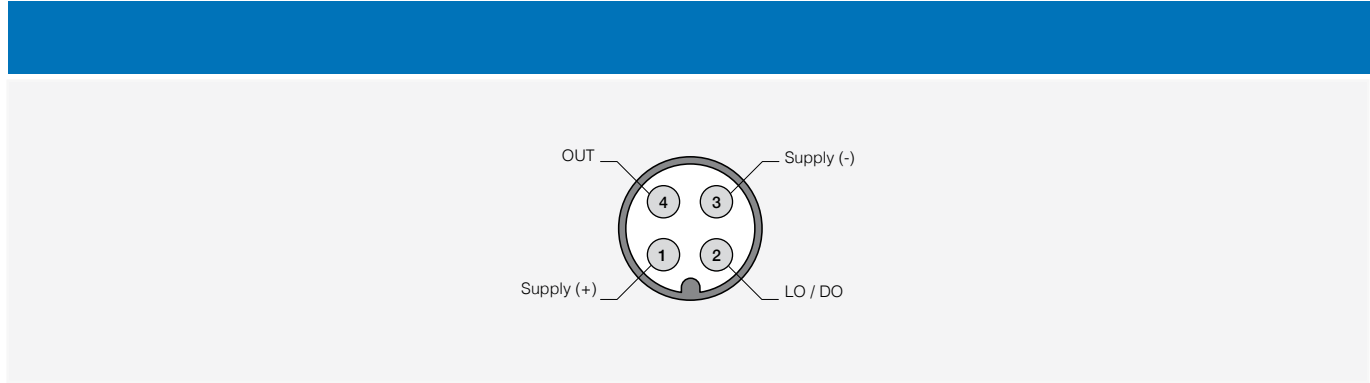

logic diagram

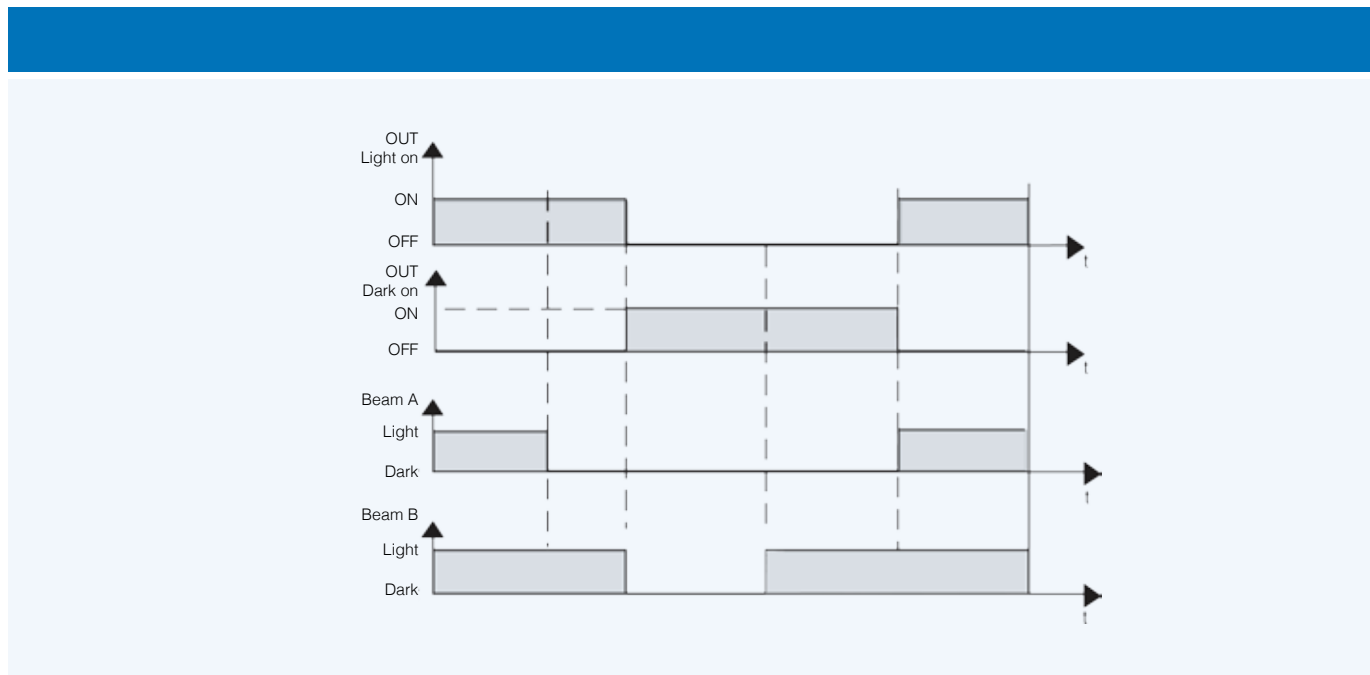

Considering A as the outer ray and B as the inner ray referring to the fork input and the DARK ON operation mode, the output is activated when both A and B are intercepted by the edge and is deactivated when both A and B are free. The hysteresis is so equal to the optical interaxes 6 mm.

A: outer ray referring to the fork input
 B: inner ray referring to the fork input



FC3/**-**

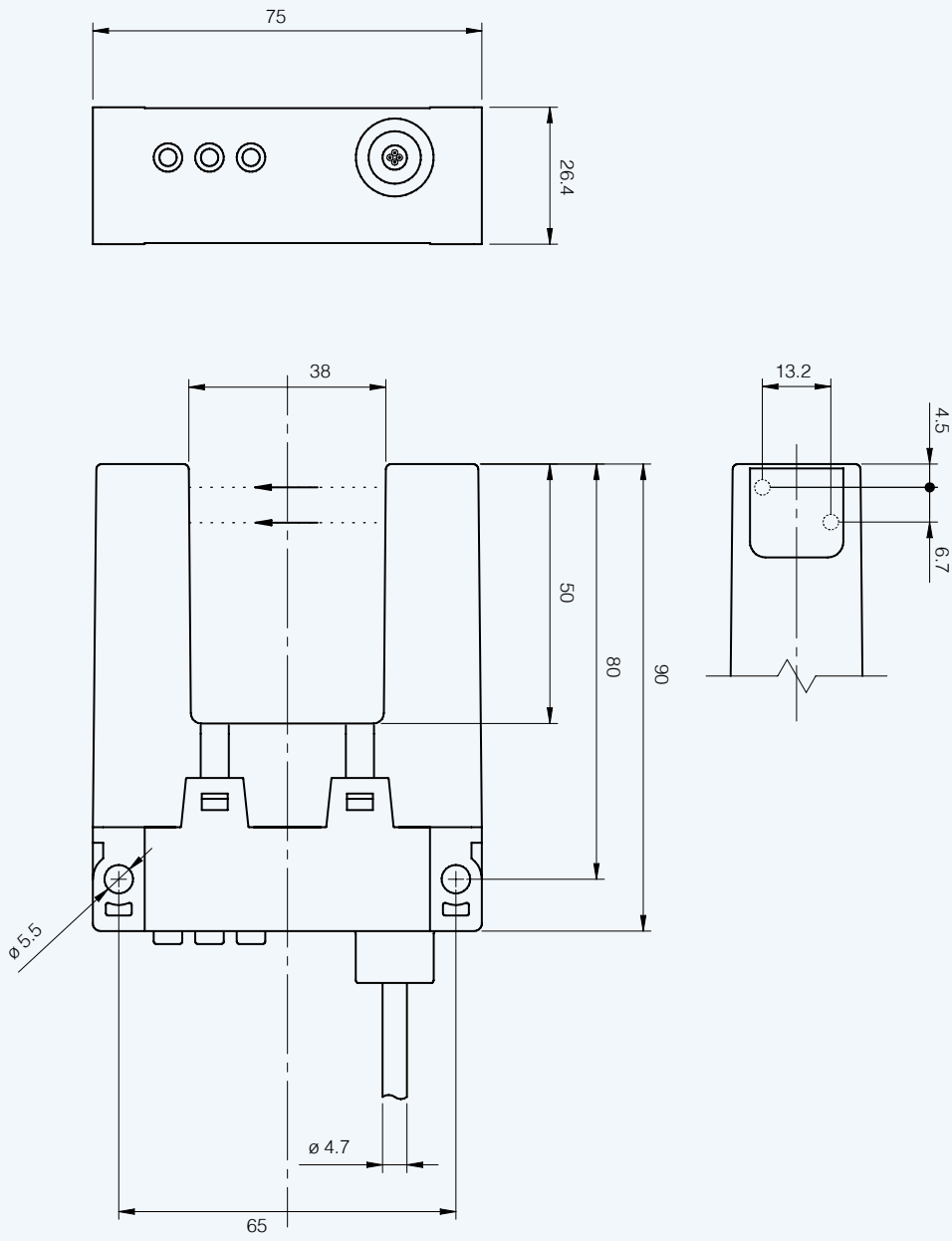



FC4 series

Four beams fork sensor for belt tracking control



Four beams slot sensor

features

- Four beams photoelectric fork sensor for belt tracking control
- Double static outputs + alarm contact
- Approvals: CE

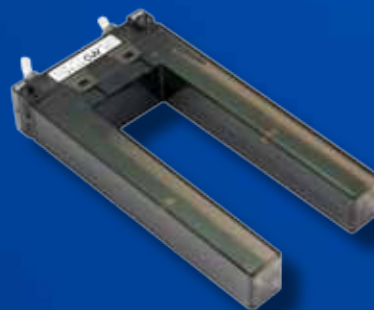

web contents



- Application notes
- Photos
- Catalogue / Manuals



ordering system

description	model
Two pig-tail, male M12 connectors, 4 pins, cable length 600 mm	FC4/V-00
Two co-axial cables, 4 pins, cable length 2,000 mm	FC4/A-00

plug



J1 plug			
pin	colour	function	description
1	brown	24 Vdc power input	power supply and common positive for loads
2	white	belt tracking output ONC	PNP NC output with short circuit protection
3	blue	0 Vdc power input	power and output return
4	black	belt tracking output ONO	PNP NO output with short circuit protection
J2 plug			
pin	colour	function	description
1	brown	not connected	can be used as input
2	white	alarm output A	pin a1 of alarm output contact
3	blue	not connected	power and output return
4	black	alarm output A	pin a2 of alarm output contact



technical specification

according to IEC EN 60947-5-2

Four beams
slot sensor

parameters	minimum	typical	maximum
sensitivity ⁽¹⁾	-	1 sheet of 80 g/m ² white paper	-
wave length	-	880 nm	-
light beam diameter (maximum obstacle diameter)	-	-	3 mm
aperture angle	± 15°		
oscillation hysteresis	7 mm		
optical power class	1 (no danger)		
ambien light rejection	10,000 lux, artificial light		
power supply voltage ^{(2) (3)}	10 Vdc	24 Vdc	30 Vdc
ripple ⁽⁴⁾	≤ 5 Vpp		
supply current ⁽⁵⁾	30 mA	-	70 mA
output A (alarm) ⁽⁶⁾	electromechanical contact, 1 A, 30 VDC, no short circuit protection		
outputs ONC and ONO (belt tracking control)	two complementary PNP outputs class DC13 (inductive load protection) short circuit and overload protection		
output current	-	200 mA	300 mA
short-circuit protection	430 mA @ 25°C		
voltage drop	-	-	2,5 V @ 100 mA
leakage current	-	≤ 10 µA	-
maximum load current	5 µF		
sampling period ⁽⁷⁾	4 ms		
scan duration of the four beams ⁽⁸⁾	600 µs		
output ONC and ONC response times	4,7 ms		
maximum output switching frequency	70 Hz with 1/2 dark/light	-	100 Hz with 1/1 dark/light
output A contact response time	-	-	8 ms (open); 500 ms (close)
time delay before availability ⁽⁹⁾	-	-	700 ms
test input levels (provision only, not connected)	LO ≤ 5 V (or open), HI * 15 V according to IEC 61131-2 (2007)		
VDE protection class	III (max. voltage 50 VAC), 500 V insulation		
index of protection	IP67		
shock resistance IEC 60068-2-27	3 axes x 6, Half sine, Acc.: 30gn, Dur.: 11 ms		
vibration resistance IEC 60068-2-6	freq.: 10...55 Hz, Amp.: 0.5 mm, Sweep: 5 min. Fr: 3 x 30 min		
EMC	in conformity with the EMC Directive according to EN 60947-5-2		
operating temperature range	-	-20 °C ...+55 °C	-
storage temperature	-	-40 °C ...+75 °C	-
humidity	15 %	-	95 %
weight	200 g		
connections	4 pins, see TABLE 1, models, TABLE 4 and TABLE 5		
housing material	PC		
cable materials	PVC		



- (1) Dark state detection, valid for all beams individually.
- (2) We recommend use of an external power supply to compensate for transient mains failures of up to 20 ms according to EN 60204.
- (3) We recommend use an external power supply with max. 1 A short circuit protection.
- (4) Must not exceed the max. or min. limits of the operating voltage range.
- (5) Excluding loads; valid for entire power supply voltage range.
- (6) Minimum load: 10m VDC, 0.01 mA. Mechanical life: 50x10⁶ oper. min. (at 3 Hz). Electrical life: 100 x 10³ oper. min. at 1 A 3 0VDC (at 0.5 Hz)
- (7) Duration of two read cycles with integration.
- (8) Scan interval between beams is 200 μ s.
- (9) Time taken, after power on, for outputs to switch from OFF to the state corresponding to the beam state.

dimensions (mm)

FC4/**_**

